

# AXCS01SRJ

## Combined PIR, Daylight and I/R Sensor

### Key Features

- For connection to iCAN networks via UIS or LCMD-10 devices.
- Excellent PIR sensitivity to small movements using Quad-Pyro technology
- Greater Sensor stability with reduced noise susceptibility
- 360 degree detection area
- Multiple PIR outputs may be used in Parallel for larger areas of coverage
- Daylight level detector with directional aspect
- Detectors sit flush mounted in the ceiling tile
- Compact 49mm Diameter size for recess installation in Chilled Beam and In fill Plate application
- Simple extension connection using RJ12 connector on rear of unit
- Supplied complete with 5 metre lead to connect to Lighting Control Systems
- CE & UKCA compliant to all relevant standards
- Designed and manufactured to ISO9001 standard

### Overview

This low voltage multi sensor combines PIR presence detection and a photocell in one compact flush mounting design. Using an RJ12 connector on the rear of the unit, this sensor can be connected to the iLight network via an iLight UIS or LCMD-10.

Ideal for intelligent lighting control systems that deploy system programmed intelligence. This multi sensor is perfect for applications where space is at a premium.

The AXCS01SRJ sensor's combined features ensure maximum energy savings as well as great flexibility for the user.



## Technical Information

Fixing: 2 x Spring Clip

Mounting Hole Diameter: 40 to 45mm Diameter depending on ceiling material

Weight: 35g

Temperature: 0 to 45°C (Non Condensing)

Supply: 12 - 24V dc (Regulated)

Construction: Circular Plastic Housing UL94 V0 rated

Load data: 8m A @ 15V

Max recommended mounting height: 3.4m

## Dimensions

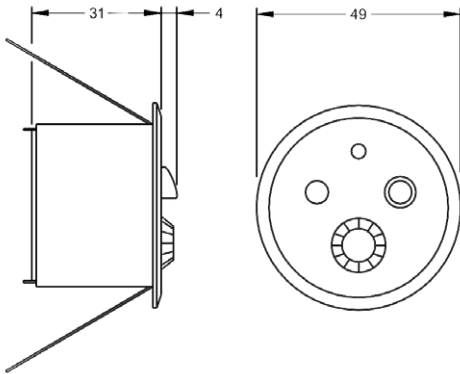

## Options



Surface mounting box - AX-SMA1  
(Order Separately)

## Typical Detection

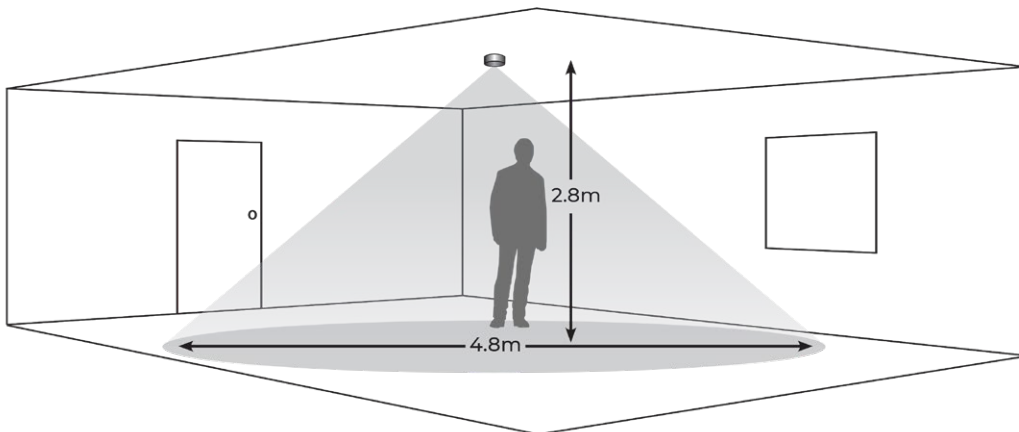

## Contact Us

+44 (0)1923 495495

[enquiries@iLight.co.uk](mailto:enquiries@iLight.co.uk)

[www.iLight.co.uk](http://www.iLight.co.uk)

### iLight

A brand of Signify  
Usk House, Llantarnam Park  
Cwmbran, NP44 3HD, UK

© 2022 Signify Holding  
All Rights Reserved

AXCS01SRJ Rev11 1022

Changes to the products, to the information contained in this document, and to prices are reserved; so are errors and omissions.

iLight is a registered trademark.  
All other trademarks are property of their respective owners.



FM 727924