

EG2 and EG2-NA

iLight Network - Ethernet Gateway

Key Features

- Connects iLight's iCANnet™ network to 10/100 Mbps Ethernet/LAN
- Configurable IP address
- Facilitates internet and Wi-Fi LAN connection into iCANnet™
- Astronomical time clock (Requires a permanent internet connection for NTP*)
- Holiday mode (Replay learned usage when absent**)
- Supports iLight applications via mobile devices (iPhone®/ iPod touch®/ iPad®)
- Supports ASCII control strings
- 16 Sequences, each with a maximum of 128 actions
- Status LEDs
- CE compliant to all relevant standards
- Designed and manufactured to ISO9001:2015 standards



Overview

The Ethernet Gateway provides a connection between an iLight network and an Ethernet LAN. This allows a user to control and configure the iLight system using iCANsoft on a LAN network PC or via the internet rather than by connecting directly into iCANnet™. Where a wireless LAN is in place (or by connecting a wireless router into the Ethernet Gateway) the user can access the network with a Wi-Fi enabled PC running iCANsoft.

The Ethernet Gateway is also the host for the iLight series of remote applications including iOS (iPhone®/ iPod touch®/ iPad®) and a webserver front end where applications are downloaded separately. Coupling the EG-2 to a WIFI network enables scene control, visual feedback and modification from your hand held device.

The Ethernet Gateway also facilitates connection to the internet when used with iCANsoft, a firewall, ISP and a Ethernet switch, this then enables remote connection for programming & obtaining diagnostics of the lighting control system.

The built in astronomical timeclock feature enables preprogrammed timed events for your lighting system. The holiday mode feature delivers an added feeling of security as the system can replay up to 2 weeks of recorded activity whilst the building is unoccupied.

The Ethernet Gateway is available in two versions:

EG2-NA - Ethernet Gateway including power supply and steel enclosure.
EG2 - Ethernet Gateway in DINrail enclosure.

Power Supply and metal DINRail enclosure available to order separately.



Mechanical - EG2

Weight: 1 kg

Operating temperature: +2°C to +40°C

Note: All enclosures must be adequately ventilated

Max storage temperature: +60°C

Humidity: +5 to 95% non-condensing

Environmental protection: IP20

Electrical - EG2

Supply: Requires 9 - 36VDC

(Optional 15V DINrail power supply available)

Protection: Fully transformer isolated ethernet

Dimensions - EG2

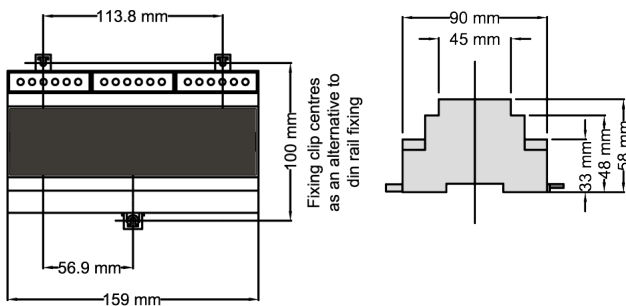

Mechanical - EG2-NA

Weight: 2.5 kg

Operating temperature: +2°C to +40°C

Note: All enclosures must be adequately ventilated

Max storage temperature: +60°C

Humidity: +5 to 95% non-condensing

Environmental protection: IP20

Electrical - EG2-NA

Supply: Requires 100 - 240 VAC

Protection: Fully transformer isolated ethernet

Terminal Sizes: iCANnet™ cable size: 5 x 1.5mm²

Dimensions - EG2-NA

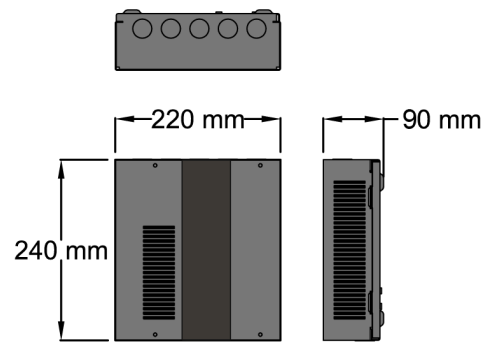

Typical Schematic

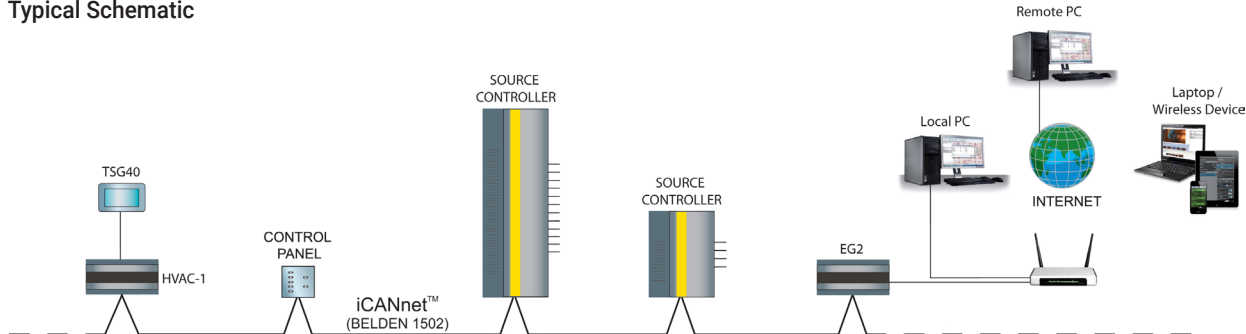

Application Download

iOS for iPhone®/ iPod touch®/ iPad® - <http://www.apple.com/itunes>

* Network time protocol

** Requires time clock to be activated and a permanent internet connection

Contact Us

+44 (0)1923 495495

enquiries@iLight.co.uk

www.iLight.co.uk

Cooper Lighting Solutions
20 Greenhill Crescent,
Watford Business Park,
Watford, Herts, WD18 8JA. UK

© 2020 Cooper Lighting Solutions
All Rights Reserved

EG2, EG2-NA Rev8 0920

Changes to the products, to the information contained in this document, and to prices are reserved; so are errors and omissions.

iLight is a registered trademark.

All other trademarks are property of their respective owners.



FM 664349