



iLight Product Catalogue

English - Issue 8.3



EATON

Powering Business Worldwide

iLight Lighting Controls

Creatively translating our clients' lighting visions into reality is at the heart of what we do.

iLight control products can be found in any environment where pre-programmed or timed lighting control is required. There are a huge variety of applications including hotels, restaurants, retail shopping developments, places of worship, conference centres, office buildings, ocean liners, theme parks, 'smart' homes and more.

The intelligence and breadth of our product range is extensive; from powerful yet easy to use software, to elegant control panels and a range of source controllers to

dim and control all load types and save energy. What's more, as our products are both practical and upgradeable, they are easy to install and economical to own.

For more than 40 years our staff have led the way setting exacting standards of service. We pride ourselves on providing rapid response to enquiries, detailed quotations and AutoCAD system drawings as well as our helpful customer support, experienced commissioning teams and flexible 24 hour maintenance contracts to complete the equation.

The iLight Product Range



Lighting control products can be found in most high quality visual environments including hotels, restaurants, retail shopping developments, places of worship, conference centres, office buildings, ocean liners, theme parks, 'smart' homes and much more.

Based on over 40 years of experience, our solutions are tuned to reflect the needs of the application and the preferences of the customer.

Our powerful, yet easy to use software, graphical interfaces, elegant control panels and behind the scenes management applications are backed up by a team of customer support, and commissioning engineers.

Our extensive range of products will switch or dim to control all load types, bringing high quality environments to life whilst saving energy too.

All our systems are designed to be practical and cost effective to install and to live with. The built in flexibility of our distributed intelligence systems means that systems are both expandable and upgradeable throughout the life of any modern building as it adapts to changing patterns of use.

Eaton Lighting Systems

Eaton Lighting Systems is a specialist lighting controls manufacturer with more than 40 years of operational expertise in the design, supply and support of lighting control systems in the architectural, entertainment and energy saving markets. Our focus is to meet your system control needs, no matter how complex or simple, through innovation, reliability and flexibility. Our portfolio of industry leading systems includes iLight Series, Zero 88 Series and Greengate Series.

Zero 88 Series

Entertainment lighting control equipment and software for theatrical and performance applications around the world.

- Lighting consoles and power control
- Colour changing LED controls
- Control of moving and effect lighting

www.zero88.com

Greengate Series

Global offering of energy management lighting controls for commercial and industrial applications for both the 230V & 110V markets.

- Flexible, scalable lighting control networks
- Occupancy sensors
- Daylight harvesting

www.greengatecontrols.co.uk

Lighting Controls Code Compliance

- Improves BREEAM & LEED scoring for building sustainability.
- Contributes to energy reduction targets under Climate Change Levy (CCL) and Carbon Reduction Commitment (CRC).
- Qualifies for Enhanced Capital Allowance (ECA) applications.
- Delivers lighting control requirements under UK Building Regs - L2a & L2b and BRE: 498.

Achievable Energy Savings

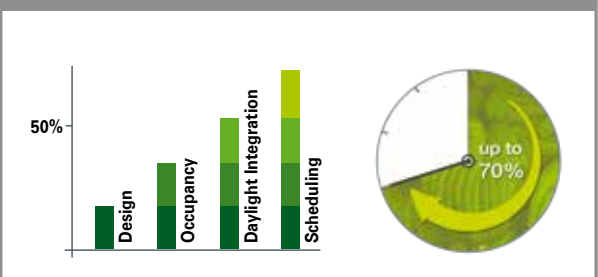

User Interfaces

iLight user interfaces are flexible, powerful and easy to use. The simplicity of one button push hides the intelligence and sophistication of the iLight control system behind it; no matter how complex the change.

A single button may instigate a series of timed events, colour changes or dynamic effects, or simply select pre-set levels and scenes to make great lighting design repeatable time after time.

Panels may be configured to match virtually any specification or finish. Touchscreens extend control capabilities with custom graphics and multiple pages to deliver against the most demanding customer requirement. All standard panels are supplied pre-loaded with a basic program for immediate use and to allow on-site testing prior to commissioning.

iLight control panels also integrate with Audio Visual and Building Management Systems for an elegant, seamless building wide control solution.



Sencia

Sencia is a range of highly refined control panels designed for good looks and flexibility.

Text legends are backlit, with engraved text or graphic legends. The ultraflush buttons are individually dimmable to user requirements. Day mode provides clear illumination whilst night mode dims buttons down to a soft non invasive light level. As well as a wide range of standard button legends, custom text and graphics can also be provided.

Buttons come in four sizes which can be used to populate either single or double column plate formats. A maximum of 12 single height buttons can be used where multiple scene control is required. Alternatively double or triple height buttons could be used to help differentiate eg. blind control functions. With white illumination as standard, button caps can also be removed to insert a colour filter to change the button colours to a range of 6 standard hues.

Key Features

- Up to 12 configurable push buttons with integral LED backlighting on a single gang panel.
- Integral programming point.
- Fully configurable functionality including room joining, sequencing and programmable logic functions.
- Flash memory for future proof upgradeability.
- Variable fade times: 0.1 seconds to 60 minutes per button.
- Dimensions: 86mm (h) x 86mm (w).
- Compatible with both standard UK back box (35mm) and European back box (40mm).
- 12Vdc powered direct from iLight network.

Custom Backlit Button Engraving Examples

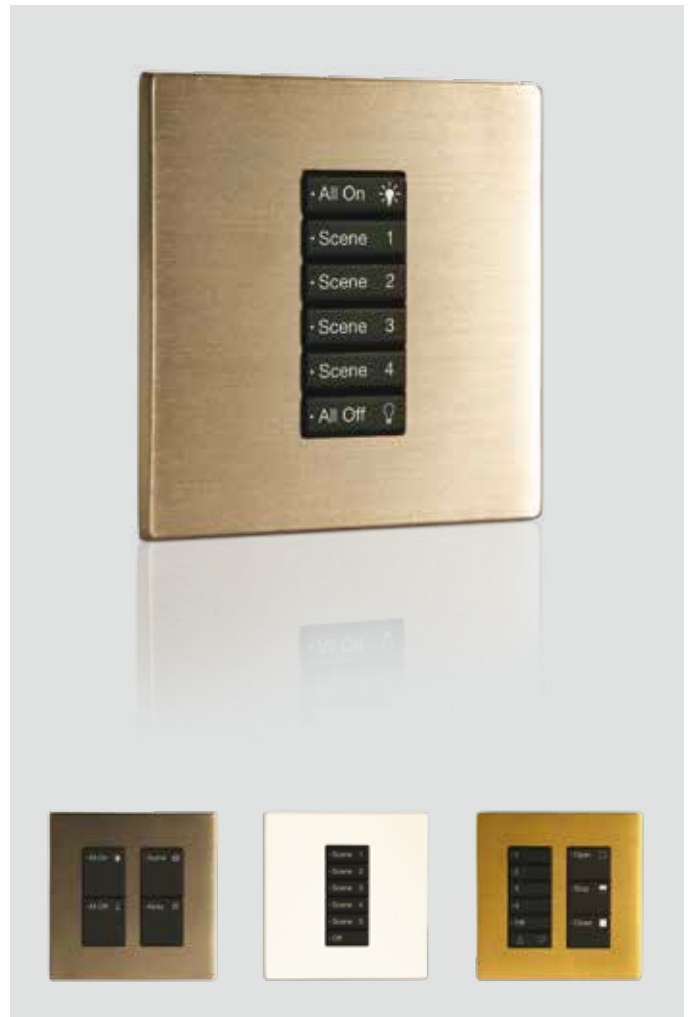
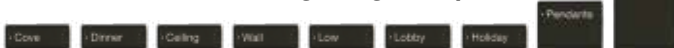

DALI

DALI control panels are available in several configurations which include the use of a large on/off button control with associated up/down adjustments and a choice of large and small buttons. Individual buttons have backlight indicator lights and strong tactile feedback. There is also a custom button engraving service making DALI control panels fully flexible to meet the needs of your project.

Key Features

- Integrated DALI communication interface.
- Draws power from the DALI communications bus to simplify wiring.
- Available in Black or White finishes.
- Standard or custom engraving on buttons.
- Compatible with standard UK back box (35mm).
- Dimensions: 86mm (h) x 86mm (w).

Custom Button Engraving Examples



User Interfaces

Kensington



Kensington control panels are designed for discretion and simplicity with panels featuring white LEDs and contemporary looks. Panels are available in a range of high quality metal finishes including, Brushed Stainless Steel, Bright Chrome, Polished Brass and White with other finishes available on special order.

Kensington control panels stand just 4mm off the wall for a sleek, elegant and modern look.

Choose between standard 2, 5, 7 and 9 button configurations with or without Infra-red control. All plates fit a 35mm deep UK single gang back box and have a screw less fixing.

Key Features

- Up to 10 push buttons per panel with integral LED indicators on a single gang panel.
- Integral RJ12 programming point.
- Optional IR remote control receiver (not available with 10 button panels).
- Fully configurable functionality including room joining, sequencing and programmable logic functions.
- Flash memory for future proof upgradeability.
- Variable fade times: 0.1 seconds to 60 minutes per button.
- Dimensions: 86mm (h) x 86mm (w).
- Fits standard 35mm deep UK back box.
- 12Vdc powered direct from iLight network.

Custom Button Engraving Examples



Classic



Classic control panels are supplied with a choice of Wandsworth Series 2 or Series 3 face plates in different finishes and configurations and with integral blue LED indicators.

Classic control panels are modular in design and are therefore completely flexible. Hardware provision allows any single gang panel to have up to 10 buttons (A double gang version is available with up to 20 buttons). This means that if control requirements of an installation change during its lifetime, buttons may be easily added or removed. All that is required is a new faceplate to match the new button configuration and a reprogram of the control panel functionality.

Key Features

- Screw type (Series 2) or Screwless (Series 3) fixing.
- Up to 10 buttons with integral LED indicators on a single gang panel and up to 20 buttons on the double gang panel.
- Integral RJ12 programming point and optional IR remote control receiver (not available with fully populated 10 or 20 button panels).
- Fully configurable functionality including room joining, sequencing and programmable logic functions.
- Keyswitch inputs.
- Flash memory for future proof upgradeability.
- Variable fade times: 0.1 seconds to 60 minutes per button.
- Dimensions: 86mm (h) x 86mm (w). Single Gang & 86mm (h) x 146mm (w) Double Gang.
- Fits standard 35mm deep UK back box.
- 12Vdc powered direct from iLight network.

Custom Button Engraving Examples



Ineo

Ineo control panels are a versatile range of specification grade control panels that set new standards in intuitive layout and operation. Users are quickly drawn to the large on/off button controls with associated up/down adjustments. Panels may be ordered engraved in up to 10 standard layouts. There is even a choice of button size and colour.

Key Features

- Available in Black, White & Ivory finishes.
- 10 standard panel layouts.
- Each button individually configurable via iCANsoft.
- Variable fade times: 0.1 seconds to 60 minutes per button.
- Built-in infrared receiver with learnable remote codes.
- Flash memory for future proof upgradeability.
- Buttons include Scene, Raise, Lower, On, Off functionality.
- 12Vdc powered direct from iLight network.
- 16 Sequences with up to 128 steps per sequence.
- Choice of large or small button caps.
- Standard or custom engraving on buttons.
- Tap on/off feature to override fade time.
- All plastic construction with a separate snap-on surround.
- Dimensions: 121mm (h) x 83mm (w).
- Requires NEMA (US Style) backbox 77mm (h) x 51mm (w) x 64mm (d). Order separately.

Custom Button Engraving Examples



Revio

Revio controls are highly intuitive touch control user interfaces that provide advanced lighting control in a high-tech design. This control eliminates end user confusion by combining an easily identifiable power button with a light icon at the centre of a rotary control, with up to 8 touch sensitive buttons under a customisable descriptive insert. While traditional rotary dimmers control just one area of lights, the Revio rotary dimmer controls multiple groups of lights either individually or together.

Key Features

- 8 touch sensitive backlit switches with the selected scene brightly lit.
- Audible feedback when a switch is activated.
- Rotary control provides raise / lower function.
- Variable fade times: 0.1 seconds to 60 minutes per button.
- Built-in infrared receiver with learnable remote codes.
- Flash memory for future proof upgradeability.
- 16 Sequences with up to 128 steps per sequence.
- Labelling, color, style, language and logos completely customisable.
- 12Vdc powered direct from iLight network.
- Tap on/off feature to override fade time.
- Dimensions: 123mm (h) x 70mm (w).
- Requires NEMA (US Style) backbox: 77 (h) x 51 (w) x 64mm (d). Order separately.

Custom Printed Inserts



Revio's printed inserts are capable of describing the unique zone or scene configurations of any project. The insert is covered in UV-protected, clear plastic providing longevity of graphics and a surface that can be wiped clean. From subtle tones to match interior decoration to personalised themes.

User Interfaces

Colour Touchscreens

LCD colour touchscreens offer the ultimate solution in flexible, intuitive and user friendly interfacing to the lighting control system and for controlling linked systems. They offer a manageable solution to control a wide range of functions in an individual location or as a central control for multiple areas.

Building plans, photos and 3D graphics can all be used to customise the display to meet individual tastes and themes.

The touchscreens can also be used to provide control of other integrated systems such as audio visual, curtains, blinds and heating systems.

Enterprise Operate PC control software allows iLight graphic control on any size screen - Ideal for control rooms or where a big impact is needed.

Enterprise Operate - Any Screen Size



Custom Graphic Examples



Key features

- TFT LCD screen with analogue touch overlay.
- 65000 Colours available.
- Selection of Bezel finishes with screwless fixing.
- Supplied with basic configuration installed.
- Standard buttons and backgrounds supplied with configuration software.
- All graphics and buttons can be customised.
- Programmable backlight level to automatically reduce screen brightness to a non-intrusive level after time out period.
- Password feature to allow different access levels.
- Large memory allows for up to 250 pages depending on graphics used.
- Touchscreen Dimensions: 86mm (h) x 146mm (w)
- Fits standard UK double gang backbox.

Functionality

- Can control an entire building or the adjacent area.
- Full graphical 'tell back' control of each and every circuit.
- Full scene set programming functions with "PIN" security options which allows the user to adjust preset levels on lighting scenes.
- Ability to input customers' graphics and building plans to provide a bespoke interface.
- Easy to use iCANsoft software for programming via built-in USB port.
- White powder coat or Stainless Steel finishes as standard. Many other finishes available on special order.

Smartphone & Tablet Apps



Residential Applications include:

- Private Homes
- Apartments
- Home Cinemas
- Hotel Suites
- Smarthomes

Ideal for extending existing mobile devices to control lighting.

Commercial Applications include:

- Meeting Rooms
- Hotel Ball Rooms
- Board Rooms
- Lecture Theatres
- Leisure and Restaurant Chains

Ideal hand held device for maintenance or operational adjustment not requiring a service engineer.

iLight mobile applications for iPhone®, iPod touch®, iPad® and Android now bring fast and intuitive control of a complete lighting system to a hand held device. Navigate floors and rooms to choose, adjust and save lighting scenes with simple touch control operation.

Mobile applications must be used in conjunction with iLight EG2 and EG2-NA Ethernet Gateway devices for network access.

At turn on, the network will recognise each mobile device and auto populate with the latest layout, scene and level settings for immediate use. Networks require initial commissioning and setup.

Installations may support multiple devices and varying security levels permitting only authorised user to make alterations.

Screen views can be personalised with custom background images via the mobile device. Area, room and floor labels may be individually tailored for the installation at setup.

Application includes demo program to preview and learn operational capabilities prior to commissioning.

Key features

- Mobile user interface for controlling iLight lighting network.
- Bi-directional control and feedback.
- Supports multiple iOS or Android devices on same network.
- Automatically loads room and scene information when connected.
- Selective password protection.
- Adjust and save changes.
- Customisable background images.
- Intuitive fader and switch icons.

 <http://www.apple.com/itunes>

 <https://play.google.com/store/apps>



Control Panel Styles, Finishes & Configurations

Sencia Panel Configuration Examples



SSR-6SB-6SB-BS-CUSTOM
12 button panel with brushed stainless steel finish.



SSR-5SB-RL-PC
4 scenes, off, raise and lower panel in polished chrome.



SSR-6SB-6SB-PC-CUSTOM
12 button custom panel with raise and lower function.



SSR-2LB-2LBLB-BS-CUSTOM
4 large button 'Front Door' style panel.







SSR-5SB-RL-3MB-BB
4 scene, off, raise, lower and blind control.



SSR-6SB-W
5 scene and off, standard scene control panel in white finish.

Finish Codes

	PB	Polished Brass
	SB	Satin Brass*
	BS	Brushed Stainless Steel
	BC	Bright Chrome
	BB	Brushed Antique Brass*
	BK	Black Nickel*
	B	Black*
	W	White

Kensington Panel Configuration Examples



XSR093IBS
9 button panel with infra-red and brushed stainless steel finish.



XRP073-AB
7 button panel with antique brass finish.



XSR023-BS
2 button panel with brushed stainless steel finish.



XRP073-W
7 button panel with white finish.



XRP073-PB
7 button panel with polished brass finish.



XSR053-BC
5 button panel with bright chrome finish.

Finish Codes

	PB	Polished Brass
	SB	Satin Brass*
	BS	Brushed Stainless Steel
	BC	Bright Chrome
	BB	Brushed Antique Brass*
	BK	Black Nickel*
	B	Black*
	W	White

DALI Panel Configuration Examples

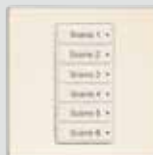



CLD-6SB-W
6 small scene buttons with white finish



CLD-2LB-RL-B
2 large scene buttons, raise and lower buttons with black finish

Finish Codes

	B	Black
	W	White

Classic Panel Configuration Examples

Finish Codes

	PB	Polished Brass		PD	Polished Desert Brass*
	AB	Antique Bronze*		BN	Bright Nickel*
	SS	Satin Stainless Steel		SN	Satin Nickel*
	MS	Mirror Stainless Steel		QZ	Quartz*
	SL	Satin Silver*		DG	Desert Gold*
	AR	Antique Brass*		LB	Light Bronze*
	AC	Antique Copper*		MB	Matt Black*
	AS	Antique Silver*		W	White
	SD	Satin Desert Brass*		CW	Cream White*

* These finishes are special order and can take a longer lead time. Classic Panels are also available in an etched primer finish ready to be colour matched to a particular RAL colour.



CSR023-SD
2 button Series 3 panel with satin desert brass finish.



CSR023-AB
2 button Series 3 panel with antique bronze finish. (Custom layout)



CSR053-MS
5 button panel with mirror stainless steel finish. (Custom engraving)



CSR053-AR
5 button Series 3 panel with antique brass finish.



CRP043-SS
4 button Series 3 panel with satin stainless steel finish.



CRP073-W
7 button Series 3 panel with a white finish. (Custom white buttons)



CRP073-PB
7 button Series 3 panel with polished brass finish.



CSR092IPB
9 button Series 2 panel with IR receiver and polished brass finish.





CSR053-KMS
5 button double gang panel with key switch function. (Custom engraving).



TSC30-W
Mini Colour Touchscreen with white surround.

Ineo Configuration Examples

Finish Codes

	B	Black
	W	White





CLS-2LB-RL-B-IR
Ineo control panel, 2 big buttons, raise/lower, on/off and integral IR in a black finish.



CLS-4SB-RL-W-IR
Ineo control panel, 4 small buttons, raise/lower, on/off and integral IR in a white finish.

Revio Configuration Examples

Finish Codes

	B	Black		G	Grey
	W	White			



CLV-44Z-RL-G-IR
Revio Wallstation, 4 buttons + 4 zones and integral IR in a grey finish.



CLV-44Z-RL-B-IR
Revio Wallstation, 4 buttons + 4 zones and integral IR in a black finish.

Software

Enterprise Software Suite



Enterprise Suite is a set of software packages for the control and operation of iLight lighting control systems. There are three packages available with different levels of control capability to cater for even the most demanding lighting control applications.

Enterprise Operate is designed to give powerful user control through a simple intuitive customised graphical interface. Actions may be manually controlled or scheduled for specific day/dates and times using the powerful astronomical timeclock scheduler.

Enterprise Floorplan adds the ability to import building and campus wide floor plans for additional control and feedback on system health.

Enterprise Suite Complete with Server includes energy usage displays and advanced graphs for greater insight into system energy consumption.

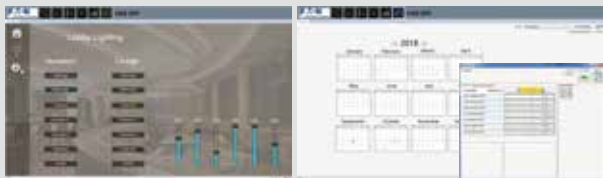

Enterprise Operate

The first level package is Enterprise Operate which consists of a fully configurable and customisable graphical user interface running on a PC or PC touch tablet. Screen pages can be custom designed to give powerful operator control of the lighting scenes in multiple areas and with the in built event scheduler, programming timeclock events provides a sophisticated level of automation.



Enterprise Floorplan

The second level software package includes Floorplan control. Floorplans can be imported into the software after commissioning stage to display a visual overview of the lighting network fitting by fitting. Lights can be controlled via this view and the network can be monitored for potential lamp failures and network faults. Enterprise Floorplan also includes the Enterprise Operate and Event Scheduler functions from the first level package.

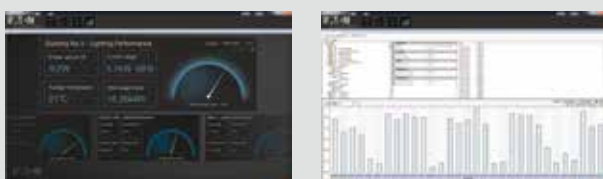

Enterprise Suite Complete

The complete Enterprise Suite adds energy consumption dials and advanced graphs to provide a comprehensive insight into the live operation of the lighting system. Graphical displays show calculated energy use in all areas while advanced graphs and reports show power usage and trending over time for analysis to help optimise energy usage. Enterprise suite is always delivered as a complete package loaded onto a suitably sized Windows Server.

Source Controllers - DINrail Mounted

Complete Panel Solutions

iLight panel solutions offer the ultimate in complete project flexibility with peace of mind. Utilising Eaton's in-house design, manufacturing and testing facilities, DINrail modules may be combined with an extensive range of Eaton enclosures, switch gear and control modules to deliver a complete, ready to install panel solution.

iLight offers a comprehensive range of module options for controlling lighting, shading and HVAC as well as integrating with AV and BMS. Multiple panels are networked to enable system wide visualisation, management and monitoring.

From a single room solution to the largest office campus, hospitality project or even a complete airport, iLight have a proven track record for delivering customised panels for projects of all scales and complexities.



DINrail Module Range



The iLight DINrail range provides a multitude of control capabilities

- Lighting load dimming with Leading edge, Trailing edge, Broadcast and fully addressable DALI, 1-10V, DSI and DMX512
- Control of all lamp types including LED, Incandescent, Fluorescent, Cold Cathode, Discharge (Metal Halide) as well as LED drivers, magnetic and electronic low voltage transformers.
- High power feed through relays for power switching of non dim loads
- Change over relays for curtain and blind control
- Interfacing with third party systems using RS232, RS485, KNX via KNX Gateways, Ethernet, BACnet, Modbus, LON



Source Controllers - DINrail Mounted

DINrail Range - Direct iCAN Network Connection

SCMD4



- 4 universe addressable DALI controller
- 64 groups per DALI universe
- iCANnet, DMX or RS485 control
- Alarm input
- Dimensions: 159x90x58 mm
- Weight: 0.35 Kg

SCMD2



- 2 universe addressable DALI controller
- 64 groups per DALI universe
- iCANnet control
- Dimensions: 159x90x58 mm
- Weight: 0.35 Kg

SCMH1200



- 12 channel digital dimming controller configured for Broadcast DALI, DSI or 1-10V output
- iCANnet or DALI control (12 addresses)
- Dimensions: 212x90x58 mm
- Weight: 0.35 Kg

SCMR0432



- 4 x 32 Amp feed through relay controller
- Max total load 64A
- iCANnet control
- Dimensions: 73x90x58 mm
- Weight: 0.3 Kg

SCMR1232



- 12 x 32 Amp feed through relay controller
- Max total load 192A
- iCANnet or DMX or DALI control (12 addresses)
- Dimensions: 212x90x58 mm
- Weight: 0.8 Kg

SCMA0402



- 4 x 2 Amp adaptive leading or trailing edge source controller
- Max total load 10A
- iCANnet control
- Dimensions: 229x90x49 mm
- Weight: 1 Kg

DINrail Range - Master & Output Modules

The MPM2400 Master Control unit is complemented by a range of low cost power modules which can be used to create a user specified solution. Modules include a choice of a 4 channel leading edge controller (SCMI), a 4 channel digital dimming controller for DALI/DSI/1-10V (SCMH), 4 & 8 channel power relay units (SCMS) and a 4 channel change over relay controller for curtain and blind control (SCMC).

- Master control of up to 48 channels of switching and dimming
- Built in system power supply
- Use with SCMI, SCMS, SCMC & SCMH modules
- Dimensions: 159x90x58 mm
- Weight: 1 Kg

Master (MPM)



MPM2400

- 4 x 2 Amp inductive leading edge source controller
- Max total load 5A
- Dimensions: 159x90x58 mm
- Weight: 1 Kg

Connects to MPM



SCMI0402

- 4 x 10 Amp switching source controllers
- Max total load 16A
- Dimensions: 159x90x58 mm
- Weight: 1 Kg

Connects to MPM



SCMS0410

- 8 x 10 Amp switching source controllers
- Max total load 16A
- Dimensions: 159x90x58 mm
- Weight: 1 Kg

Connects to MPM



SCMS0810

- 4 x 10 Amp change over relay & HF controller
- 4 x Independent low voltage outputs
- Max total load 40A (Single phase)
- Dimensions: 159x90x58 mm
- Weight: 1 Kg

Connects to MPM



SCMC0410

- 4 x 10 Amp digital dimming controller
- Broadcast DALI, DSI or 1-10V output
- Max total load 16A
- Dimensions: 159x90x58 mm
- Weight: 1 Kg

Connects to MPM



SCMH0410

Source Controllers - Fixed Format Wall Mounted

Internal view

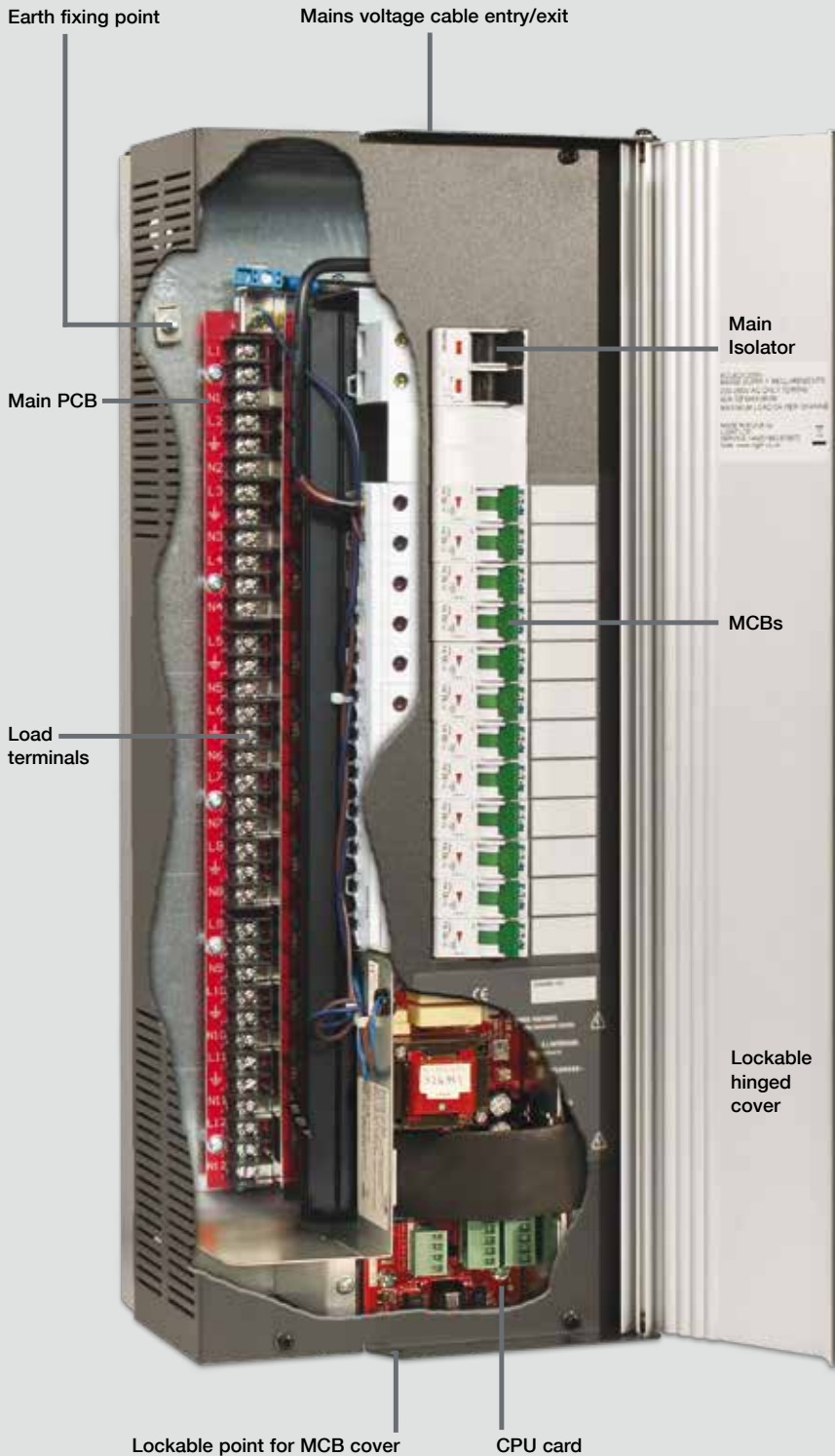

iLight fixed format source controllers are mechanically elegant, safe and practical to use.

The iLight range of convection cooled source controllers may be configured for a wide variety of breaker and load types making them one of the most versatile and flexible control solutions on the market today.

A wealth of detailed features such as lockable hinged doors and top and bottom cable access make these units suitable for installation in almost any location, contractor friendly and convenient to live with.

Variations

Inductive Source Controllers

Dim resistive, inductive and low voltage electronic transformer loads (that are compatible with leading edge dimmers).

Adaptive Source Controllers

Controller outputs can be adapted to resistive, inductive and capacitive load types. Very quiet operation.

Complete with iProtect lamp protection and auto short circuit protection. Channels may be selected for leading and trailing edge operation.

LED Source Controllers

Dim resistive and electronic loads (trailing edge). Very quiet operation. Complete with iProtect lamp protection and auto short circuit protection.

Combined Controllers

Cost effective combined controller for inductive, HF ballast and switched loads.

Suitable for AV applications.

4 circuits of inductive, 4 circuits of Broadcast DALI, DSI or 1-10V ballast control and 4 relays for power switching of non-dim loads.

Digital Dimming Controllers

Suitable for Broadcast DALI, DSI or 1-10 volt control configurable from iCANsoft. 230V switched relay outputs.

Switched Relay Controllers

Switching of resistive, inductive or capacitive lighting loads. Quiet operation.



Trailing Edge Source Controllers - Suitable for Mains LED dimming

- 4 x 5 Amp trailing edge source controller module
- Suitable for 20 Amp single phase supply
- No minimum load
- Silent operation
- MCB protection behind lockable hinged cover
- Dimensions: 280x220x155mm (D - 400x220x155mm. RCBO & RCBOX - 340x255x155mm)
- Weight: 4 Kg (RCBO & RCBOX - 4.5 Kg)

Not suitable for magnetic loads. Input isolator only included on RCBO and RCBOX versions



SCLED0405S
SCLED0405N
SCLED0405D
SCLED0405RCBO
SCLED0405RCBOX

- 12 x 5 Amp trailing edge source controller module
- Suitable for 40 Amp single phase supply
- No minimum load
- Silent operation
- MCB protection behind lockable hinged cover
- Input isolator included (except 'D' version)
- Dimensions: 550x220x155mm (D - 690x220x155mm. RCBO & RCBOX - 550x255x155mm)
- Weight: 10 Kg (RCBO & RCBOX - 11.5 Kg)

Not suitable for magnetic loads.



SCLED1205S
SCLED1205N
SCLED1205D
SCLED1205RCBO
SCLED1205RCBOX

Leading Edge Source Controllers

- 4 channel inductive source controller module
- Available in 5, 10 and 20 Amp versions
- MCB protection behind lockable hinged cover
- Dimensions

SCI0405S/N	280x220x155mm
SCI0405D, SCI0410S/N/D/RCBO/RCBOX	400x220x155mm
SCI0405RCBO/RCBOX	340x255x155mm
SCI0420S/N	375x330x155mm
SCI0420D	450x330x155mm
SCI0420RCBO/RCBOX	Consult iLight
- Weight

SCI0405S/N/D	4 Kg
SCI0405RCBO/RCBOX	4.5 Kg
SCI0410S/N	7 Kg
SCI0410D/RCBO/RCBOX	8 Kg
SCI0420S/N	9 Kg
SCI0420D	12 Kg
SCI0420RCBO/RCBOX	Consult iLight

Input isolator only included on RCBO and RCBOX versions

05 / 10 / 20 Amps per channel



SCI04 **S**
SCI04 **N**
SCI04 **D**
SCI04 **RCBO**
SCI04 **RCBOX**

- 12 channel inductive source controller module
- Available in 5, 10 and 20 Amp versions
- MCB protection behind lockable hinged cover
- Input isolator included (except 'D' version)
- Dimensions

SCI1205S/N	550x220x155mm
SCI1205D	690x220x155mm
SCI1205RCBO/RCBOX	550x255x155mm
SCI1210S/N/D, SCI1220S/N/D	850x330x155mm
SCI1210RCBO/RCBOX, SCI1220RCBO/RCBOX	850x374x155mm
- Weight

SCI1205S/N/D	10 Kg
SCI1205RCBO/RCBOX	11.5 Kg
SCI1210S/N	18 Kg
SCI1210D/RCBO/RCBOX	19.5 Kg
SCI1220S/N/RCBO/RCBOX	22 Kg
SCI1220D	23.5 Kg

05 / 10 / 20 Amps per channel



SCI12 **S**
SCI12 **N**
SCI12 **D**
SCI12 **RCBO**
SCI12 **RCBOX**

Source Controllers - Fixed Format Wall Mounted

Broadcast DALI, DSI or 1-10V Source Controllers

SCH0410S
SCH0410N
SCH0410D
SCH0410RCBO
SCH0410RCBOX



- 4 x 10 Amp HF ballast controller module
- Broadcast DALI, DSI or 1-10V control
- Suitable for 40 Amp single phase supply
- MCB protection behind lockable hinged cover
- Dimensions: 280x220x155mm
(D - 400x220x155mm. RCBO & RCBOX - 340x255x155mm)
- Weight: 4 Kg (D, RCBO & RCBOX - 5 Kg)

Input isolator only included on RCBO and RCBOX versions

SCH12 10 / 20 Amps per channel
SCH12 S
SCH12 N
SCH12 D
SCH12 RCBO
SCH12 RCBOX



- 12 channel HF ballast controller module
- Broadcast DALI, DSI or 1-10V control
- SCH1210 suitable for 40 Amp 3 phase supply
- SCH1220 suitable for 80 Amp 3 phase supply
- MCB protection behind lockable hinged cover
- Input isolator included (except 'D' version)
- Dimensions: 550x220x155mm
(D - 690x220x155mm. RCBO & RCBOX - 550x255x155mm)
- Weight: 9 Kg (D, RCBO & RCBOX - 10.5 Kg)

Switched Relay Source Controllers

SCS04 10 / 20 Amps per channel
SCS04 S
SCS04 N
SCS04 D
SCS04 RCBO
SCS04 RCBOX



- 4 channel switched relay source controller module
- SCS0410 suitable for 40 Amp single phase supply
- SCS0420 suitable for 80 Amp single phase supply
- MCB protection behind lockable hinged cover
- Dimensions

SCH0410S/N, SCH0420S/N	280x220x155mm
SCH0410D, SCH0420D	400x220x155mm
SCH0410RCBO/RCBOX, SCH0420RCBO/RCBOX	340x255x155mm
- Weight

SCH0410S/N, SCH0420S/N	4 Kg
SCH0410D/RCBO/RCBOX, SCH0420D/RCBO/RCBOX	5 Kg

Input isolator only included on RCBO and RCBOX versions

SCS12 10 / 20 Amps per channel
SCS12 S
SCS12 N
SCS12 D
SCS12 RCBO
SCS12 RCBOX



- 12 x 10 Amp switched relay source controller module
- SCS1210 suitable for 40 Amp 3 phase supply
- SCS1220 suitable for 80 Amp 3 phase supply
- MCB protection behind lockable hinged cover
- Input isolator included (except 'D' version)
- Dimensions

SCH1210S/N, SCH1220S/N	550x220x155mm
SCH1210D, SCH1220D	690x220x155mm
SCH1210RCBO/RCBOX, SCH1220RCBO/RCBOX	550x255x155mm
- Weight

SCH1210S/N, SCH1220S/N	9 Kg
SCH1210D/RCBO/RCBOX, SCH1220D/RCBO/RCBOX	10.5 Kg

Adaptive Leading or Trailing Edge Source Controllers

- 4 x 10 Amp adaptive source controller module
 - Suitable for 40 Amp single phase supply
 - MCB protection behind lockable hinged cover
 - Dimensions: 375x330x155mm (RCBO & RCBOX - Consult iLight)
 - Weight: 9 Kg (SCA0410D - 10 Kg)
- Input isolator not included

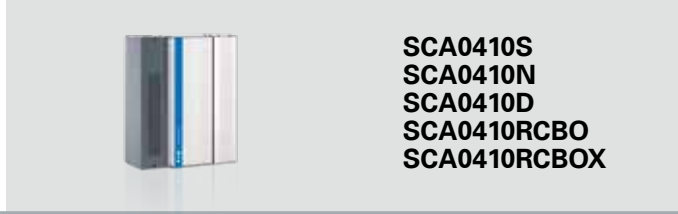

- 12 x 10 Amp adaptive source controller module
 - Suitable for 40 Amp 3 phase supply
 - MCB protection behind lockable hinged cover
 - Dimensions: 850x330x155mm (RCBO & RCBOX - Consult iLight)
 - Weight: 18 Kg (SCA1210D - 19.5 Kg)
- Input isolator not included

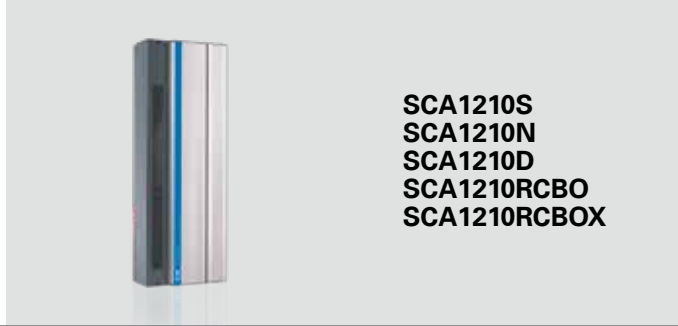

Combined Leading Edge, Broadcast DALI/DSI/1-10V Source Controller

- 8 x 5 Amp combined source controller, 40 Amp single phase supply
 - 4 circuits of inductive leading edge, 4 circuits of Broadcast DALI, DSI or 1-10V control and 4 relays for power switching of non-dim loads.
 - Dimensions 400x220x155mm (RCBO & RCBOX - 440x255x155mm)
 - Weight: 7 Kg (RCBO & RCBOX - 8 Kg)
- Input isolator only included on RCBO and RCBOX versions



DMX Source Controllers

- The SCD24 is a 24 channel DMX source controller. It is designed to provide scene set dimming output for any DMX512 controlled load.
- 24 channels.
 - 128 scene memory
 - 8 sequences with a maximum of 30 actions
 - Dimensions: 240x220x90 mm
 - 2.5 Kg



- The SCD96 is a 96 channel DMX source controller designed to provide scene set dimming output for any DMX512 controlled load. The unit also incorporates 8 general purpose 3A change over relays which are DMX addressable as some of the 96 channel DMX outputs.
- 96 channels
 - 8 x 3A general rating change over relays
 - 128 scene memory
 - 16 sequences with a maximum of 128 actions
 - Dimensions: 240x220x90 mm
 - 2.5 Kg



- The SCD Server Pro is a 19" rack mounted, fully featured, DMX lighting control system ideal for use in larger performance installations and networks where show replay, tracking backup or standalone operation is required. SCD Server Pro has 2048 channels (upgradeable to 4096)
- A stand alone or remotely controlled event replay controller for complex permanent installations such as facades, landscapes or theme parks.
 - A fully tracking Backup to any Zero 88 ZerOS lighting console
 - A bridge between a performance lighting system and an architectural lighting control network making it ideal for theatres, conference centres and other public building applications.



Network Interfaces

The iLight range of integration tools assist with the construction and configuration of the iCAN network and provide interfacing with external system components.

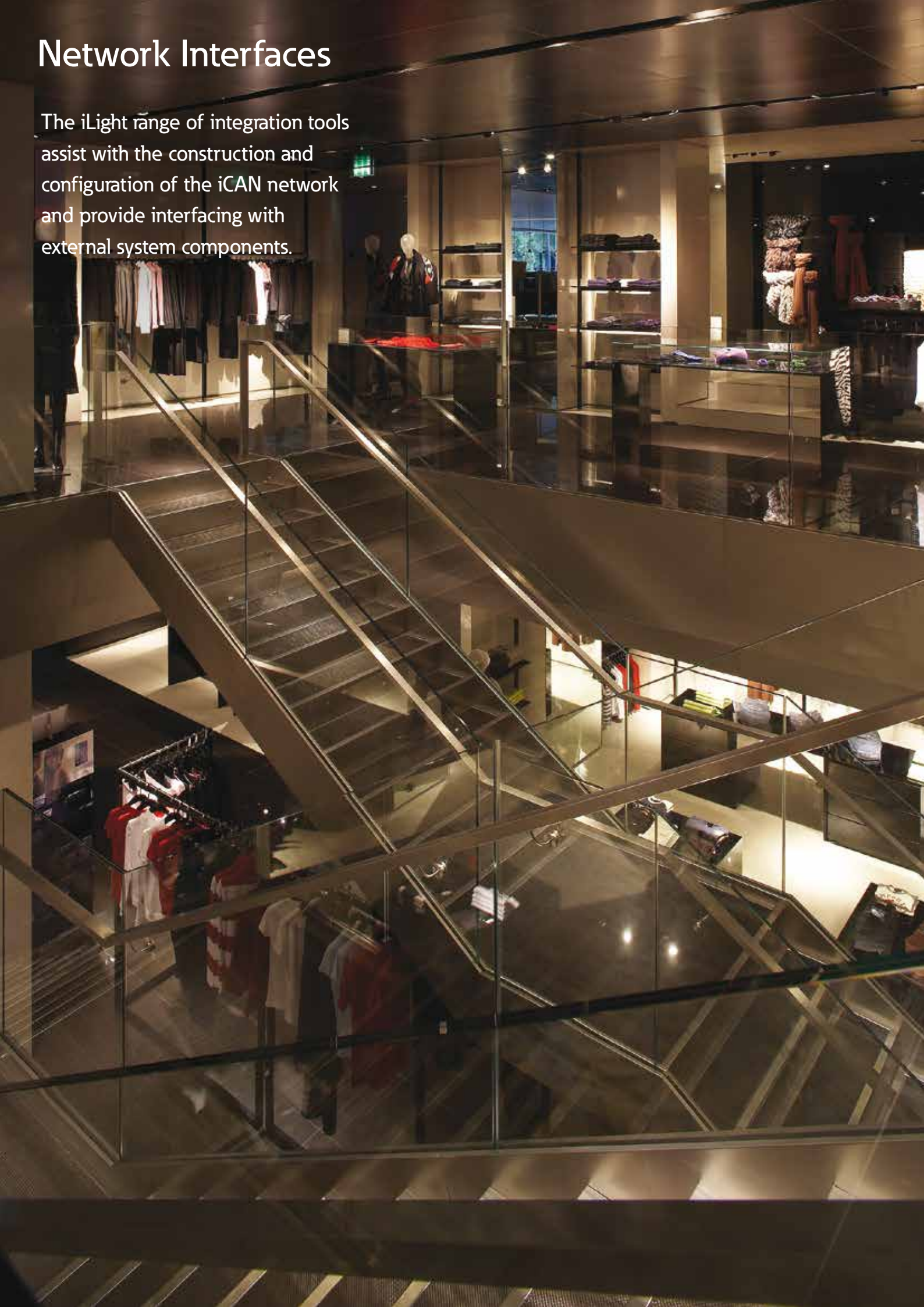

Network Interfaces

Ethernet Gateway

The Ethernet Gateway provides a connection between an iCAN network and an Ethernet LAN. This allows a user to control and configure the iLight system using iCANSOFT on a LAN network PC or via the internet rather than by connecting directly into the iLight network. Where a wireless LAN is in place (or by connecting a wireless router into the Ethernet Gateway) the user can access the network with a Wi-Fi enabled PC.

The Ethernet Gateway is also the host for the iLight series of remote applications including Android and iOS (iPhone®/ iPod touch®/ iPad®). Coupling the EG-2 to a WIFI network enables secure scene control, visual feedback and modification from your hand held device.

The Ethernet Gateway also facilitates connection to the internet when used with iCANSOFT, a firewall, ISP and a Ethernet switch, this then enables remote connection for controlling, programming & obtaining diagnostics of the lighting control system.

- Connects iLight CAN network to 10/100 Mbps Ethernet/LAN.
- Configurable IP address.
- Facilitates internet and Wi-Fi LAN connection into the iLight network.
- Time clock. (Requires a permanent internet connection for network time protocol)
- Holiday mode - Replay learned usage when absent (Requires time clock to be activated and a permanent internet connection)
- Supports iLight applications via mobile devices. Android and iOS (iPhone®/ iPod touch®/ iPad®)
- Supports ASCII control strings.
- 16 Sequences, each with a maximum of 128 actions.

The Ethernet Gateway is available in two versions:

EG2 - Ethernet Gateway in DINrail enclosure (power supply and metal DINrail enclosure available to order separately).

- Dimensions: 160x90x58 mm
- 1 Kg

EG2-NA - Ethernet Gateway including power supply and steel enclosure.

- Dimensions: 240x220x90 mm
- 2.5 Kg



EG2



EG2-NA

System Integrator Node

The bi-directional System Integrator Node allows control of a wide range of RS232 compatible third party equipment through the iLight user interfaces including audio systems, TVs, projectors, blinds, curtains, heating and HVAC systems, security & fire alarms, surveillance and CCTV.

- Configurable RS232 COMMS via 9 pin female D type (Send/Receive)
- Adjustable baud rates of 1200, 2400, 4800, 9600, 19200, 38400, 57600, 115200
- 1 x CAN bus data connection via screw terminals
- Status LEDs
- 20 programmable serial commands - triggered from the iLight network
- 16 sequences each with a maximum of 128 actions
- Dimensions: 124x49x23 mm



SI2

Network Interfaces

Relay Interface

RI2



The Relay Interface provides a versatile interface between the iLight network and other control systems. The unit is fully configurable and may be programmed to perform switching functions for curtain or blind control, AV and presentation equipment or drive contactors for heavier power applications.

- 8 relay outputs
- 8 inputs - programmable as analogue or digital used for volt free switches or motion detectors
- 16 sequences each with a maximum of 128 actions
- Audio Visual RS485 port, 2 alarm inputs
- Dimensions: 240x220x90 mm
- 2.5 Kg

Optional Plugin DMX Interface Board

DI1



Plugin interface board for DMX control input to any wall mounted source controller (When installed, RS485 port is no longer available for ASCII control using RS485).

Note: Does not fit DINrail devices

Network Bridge & Repeaters

BN2



The BN-2 bridging module allows 2 or more iCAN network segments to be connected together or arranged logically into floors or areas for ease of management. The bridge is also used to extend the network as a repeater where longer network segments or large numbers of devices are required. BN-2 also allows network messages to be filtered to ensure optimal performance in larger networks.

- Repeater where cable lengths exceed network limits
- 16 sequences each with a maximum of 128 actions
- Programmable sequence capability
- Message filtering and isolation for large networks
- Dimensions: 124x49x23 mm

CR1-RJ



The DINrail mount CR1-RJ network repeater allows 2 or more iCAN network segments to be connected together. The repeater is also used to extend the network where more than 500m of cabling is required or more than 100 network devices are used on one segment.

CR1-RJ is also ideal for creating a local segment in an equipment panel featuring power and data indications for each segment and a plug in point for panel programming.

Note: This product does not provide galvanic isolation between the A and B sides. If galvanic isolation is required, use iLight BN2

- Dimensions: 90x58x53.5mm

BMS Interface

The BMS Interface supports a wide range of control protocols to act as a bridge between Eaton's intelligent lighting control networks and a central BMS management system.

- Connectivity: LON, BACnet, Modbus
- 200 areas (points) supported. (Consult iLight for >200)
- Configurable using built in web server
- DINrail mounted
- Compatible with iLight and Greengate lighting control systems
- Dimension: 157x98x59mm (ex. connectors)
- Weight: 0.275 kg

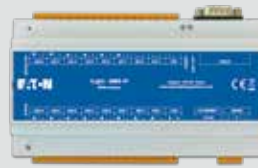

BMS-1F

Sensor Interface

The UIS features 3 sensor inputs for connecting analogue or third party sensors to the iLight lighting control network. Each sensor input is suitable for either a single occupancy detector or daylight sensor or a combined PIR, Photocell with built in infra-red control.

Each UIS installed adds three independent daylight linking engines to the network making this unit ideal for maximising daylight harvesting across all areas.

This small compact device can be deployed anywhere on the iLight network and uses RJ12 sockets and cables for fast installation.

- 3 x connections for sensors to iCAN network
- RJ12 type sockets for rapid sensor connection
- 3 independent daylight linking engines
- Presence or absence detection support
- Infra-red support for HH17IR remote controller
- Supports Infra-red identification
- 16 Sequences, each with a maximum of 128 actions
- Status LEDs
- Message filtering and isolation for large networks
- Dimensions: 124x49x23 mm



UIS

Universal Interface (UIG2)

The UIG2 allows other items such as partition switches to provide inputs to the iLight network. When configured for a room join, moving the partition will open or close a magnetic proximity switch contact (not included) and automatically re-program the function of the control panels within the room.

- 4 x 0-10V analogue inputs for volt free switches or motion detectors
- 4 volt free contact closure inputs
- 4 switch outputs for LED indication
- 16 sequences each with a maximum of 128 actions
- Fits standard UK style double gang 47mm deep back box



UIG2

Mini Universal Interface (UIM)

The UIM allows other items to provide inputs to the iLight network and is often used with third party and custom faders and switches.

- 6 inputs which each can be individually configured as 0-10V analogue, digital or photoelectric cell inputs
- 8 sequences with up to 30 steps per sequence
- Only 42mm Ø so easily fits in European and UK junction and back boxes



UIM

Sensors

iCANnet Network Sensor

NS-3



Network Sensor with Combined PIR, Daylight and Infrared Control

- Connected directly to the iLight Network via CAN terminals
- PIR detection optimised for small movement
- IR receiver for HH17IR
- Coverage: 7m Ø at 2.8m ceiling height
- Dimensions: 49mm Ø x 35mm Depth

DALI Sensors

**FLT-MTS6-DALI
FLT-MTS12-DALI**



DALI Ceiling Sensor with PIR and Daylight Sensing

- FLT-MTS6-DALI Coverage: 4.5m Ø at 2.4m ceiling height
- FLT-MTS12-DALI Coverage: 9m Ø at 2.4m ceiling height
- Draws power from the DALI communication bus to eliminate the need for external power packs
- DALI power consumption: 3.75mA
- Dimensions: 91mm Ø x 36mm Depth

PPAD-C-HB-DALI-ADDR



DALI Ceiling Sensor, High Bay PIR Presence/Absence Detector

High sensitivity PIR detector suitable for high bay applications where high detection sensitivity is needed.

- Coverage: 40m Ø at 15m ceiling height
- Draws power from the DALI communication bus to eliminate the need for external power packs
- DALI power consumption: 8mA
- Dimensions: 88mm Ø x 112mm Depth

Low Voltage Sensors

PE2EXT



External IP65 Photocell

- Low voltage exterior Photocell Detector
- Daylight sensitivity range approx 0-2,000 lux
- IP65 rated.
- Dimensions: 70x50x35mm

May be used with UIM and UIS - See Page 25

AXCS01SRJ



Low Voltage Sensor with Combined PIR, Daylight and Infrared Control

- PIR detection optimised for small movement
- Coverage: 7m Ø at 2.8m ceiling height
- Dimensions: 49mm Ø x 35mm Depth

May be used with UIS - See Page 25

A range of custom sensor solutions are also available, consult iLight with your specific requirements.

Accessories

Astronomical Time Clock

The TC-1 is a surface mounting electronic time clock with astronomical facility and LCD display. It connects to the iLight network and is fully programmable using either the front panel keyboard or iCANsoft™ PC based software for daily or date specific events.

- 255 events
- 8 sequences with up to 30 steps per sequence
- Scene selection and programming
- Channel level raise and lower



TC1

IR Transmitter

iLight hand held remote

- 8 scene buttons
- Off button
- Raise and lower controls
- 6 additional configurable buttons



HH17IR

iCANnet Network Cable

iCANnet Network Cable is specifically designed to connect between each device on an iLight control system. The cable consists of 2 x 18 AWG tinned copper wire with PE Insulation (Power pair) and 2 x 22 AWG screened tinned copper wire with PE Insulation (data pair). There is also a tinned copper drain wire in contact with the aluminium foil screen. The cable is low smoke zero halogen (LSZH) rated.



iCANnet Cable

DALI DAC

DALI Digital to Analogue Converter

Built-in relay and 1-10V current sinking interface used to integrate individual or a group of dimmable 1-10V ballasts/drivers to iLight's DALI lighting control system.

- Ultra low profile form factor designed to fit inside most ballast compartments
- Powered by the DALI bus
- Automatic detection of the DALI Bus power loss with default to closed, i.e. on or 100% position
- DALI power consumption: 3.75mA
- Dimensions: 100x28.6x25.4mm



FLT-DAC-DALI

DALI Field Relay

The iLight Field Relay provides On/Off control and network connectivity. It uses advanced switching technology specifically designed to handle the large inrush currents and inductive loads found in lighting applications.

- Maximum Load: 20 Amps
- Automatic loss of power detection defaults relay to closed (On) position
- DALI power consumption: 3.75mA
- Dimensions: 88x80x39 mm



FLT-HPRS-DALI

DALI Input Unit

Enables customer specified switches, sensors, time clocks or other on/off control devices to be incorporated into a standard DALI installation.

- Powered from DALI bus, compatible with standard DALI rating
- Up to four user configurable inputs
- DALI power consumption < 9 mA
- Dimensions: 41x20x4 mm (Cable length: 158mm)



DALI-I-U

Network overview

One network - fully scalable

The iLight network has been designed to offer total freedom and flexibility in system design.

The iLight network features distributed data processing and is truly scalable from 2 to 65,000 devices. There are virtually no limits as to what can be added to the system and with no central memory, components can easily be added or removed as required without major redesign.

The extensive iLight product range includes source controllers, interfaces and accessories that provide control solutions across residential, commercial and entertainment style projects. All common communications protocols are catered for, ensuring that the iLight system seamlessly integrates with other control components within an installation.

Network cabling may be undertaken using Eaton iCANnet cable or alternatively industry standard cable types eg. Belden 1502R.

Connectivity

The iLight system provides connectivity to the following protocols;

- DALI
- 1-10V
- DSI
- CAN
- RS232
- RS485
- DMX512
- KNX via KNX Gateways
- Ethernet
- BACnet
- Modbus
- LON

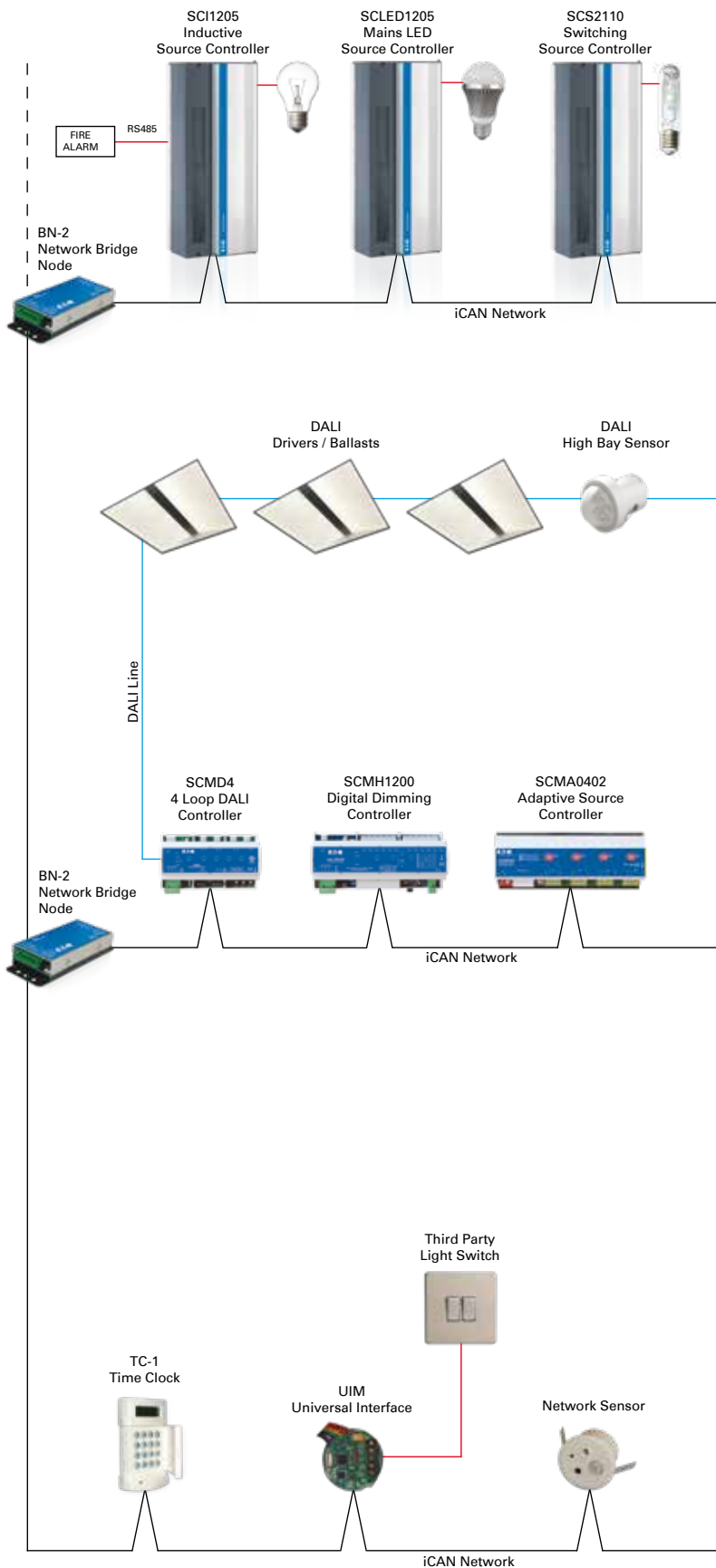

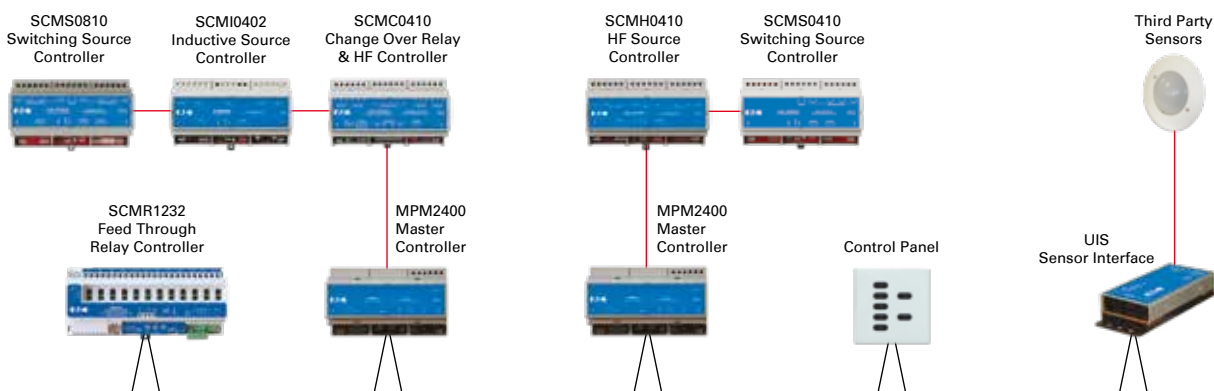
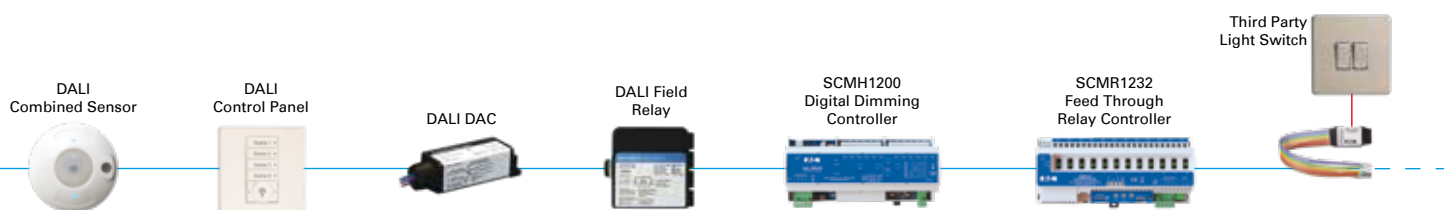
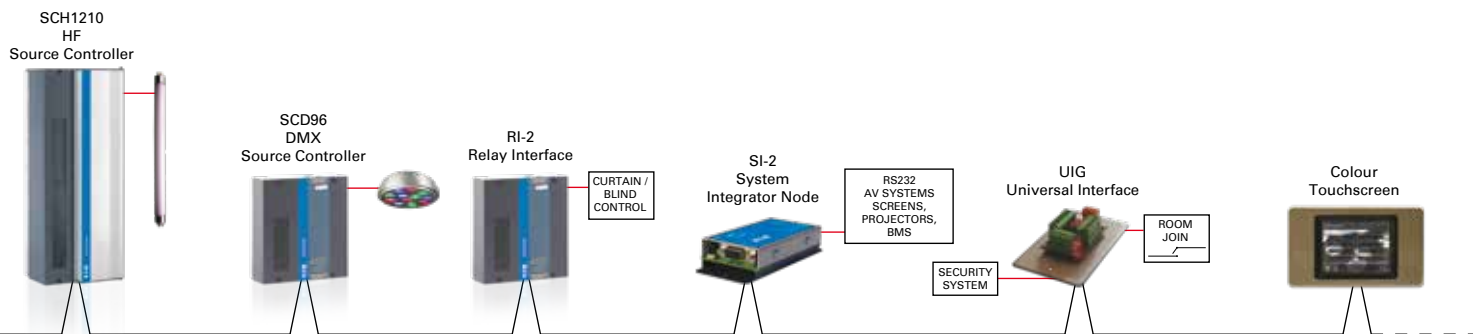

Example Project Riser Drawing

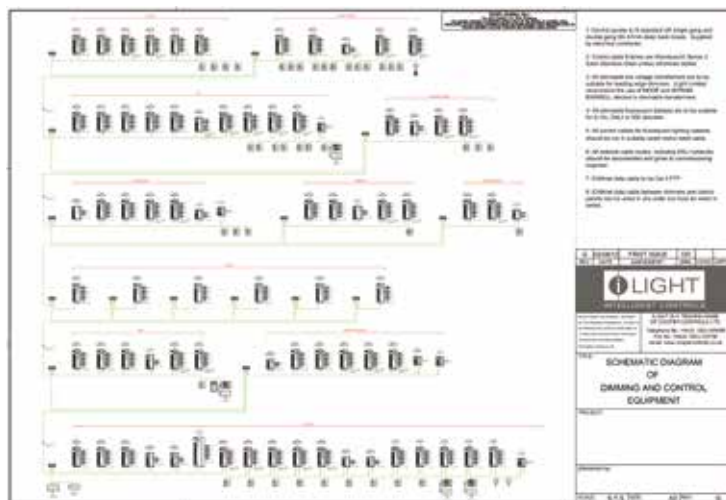
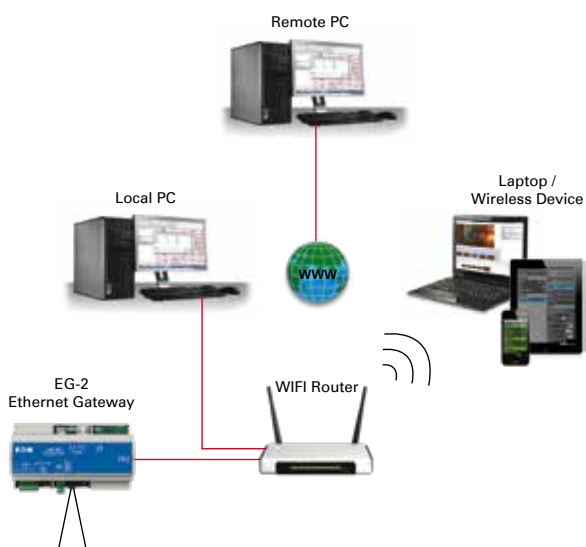

Eaton's electrical business is a global leader with expertise in power distribution and circuit protection; backup power protection; control and automation; lighting and security; structural solutions and wiring devices; solutions for harsh and hazardous environments; and engineering services. Eaton innovation is powering what matters across industries and around the world, helping customers solve their most critical electrical power management challenges.

Eaton is a power management company with 2017 sales of \$20.4 billion. We provide energy-efficient solutions that help our customers effectively manage electrical, hydraulic and mechanical power more efficiently, safely and sustainably. Eaton is dedicated to improving the quality of life and the environment through the use of power management technologies and services. Eaton has approximately 98,000 employees and sells products to customers in more than 175 countries. For more information, visit www.eaton.com.

Contact your local Eaton office

T: +44 (0)1923 495495
F: +44 (0)1923 228796
E: enquiries@iLight.co.uk
www.iLight.co.uk

Eaton Lighting Systems
20 Greenhill Crescent,
Watford Business Park,
Watford, Herts, WD18 8JA. UK
eatonlightingsystems.com

© Copyright 2019 Eaton
All Rights Reserved

Stock Number: ILM05 Issue: 8.3

Changes to the products, to the information contained in this document, and to prices are reserved; so are errors and omissions.

Eaton is a registered trademark.

All other trademarks are property of their respective owners.