

SCI1205

12 Channel x 5 Amp Inductive Lighting Source Controller

Key Features

- 12 x 5 Amp rated source controller
- Dims resistive, inductive and low voltage electronic transformer loads (that are compatible with leading edge dimmers)
- Quiet operation
- 128 scene memory
- Multiple choice of circuit protection
- Security door for MCBs
- Optional RCBO per channel
- Fail to full safety feature
- iCAN network inputs
- DMX input option
- Audio Visual Port (RS485)
- Panic/Fire alarm input
- Configuration stored in Non Volatile EEPROM
- Firmware storage in reflashable FLASH memory over iCAN network
- CE compliant to all relevant standards
- Designed and manufactured to ISO9001:2015 standards

Overview

This 12 circuit economy source controller is fully rated for 12 x 5 Amps of continuous inductive or resistive lighting loads. Whether used for tungsten, low voltage or cold cathode light sources, this unit will provide reliable service over many years. With a 128 scene integral memory, this device offers multiple control options, to meet the most demanding specifications.

In addition to iLight's iCAN network connectivity, it also has an audio visual port, and panic/fire alarm input. It is typically used on its own in areas that need manageable and controlled light such as themed restaurants, visitor centres, art galleries, and churches, or as part of a comprehensive network in large building complexes.



Mechanical Data

Weight: 10kg

Mains Cable Access:

12 x 25.5mm and 1 x 38mm knockouts

Control Cable Access: 1 x 25.5mm knockout

Operating Conditions

Operating temperature: +2°C to +40°C

Relative humidity: +5 to 95% non condensing

Connections

Two sets of terminals for the iCANnet™ network

Suitable for Belden 1502

One RJ12 socket for programming the iCANnet™ network

One set of terminals for the Audio Visual Port, RS485

One set of terminals for the panic/fire alarm input

Dimensions

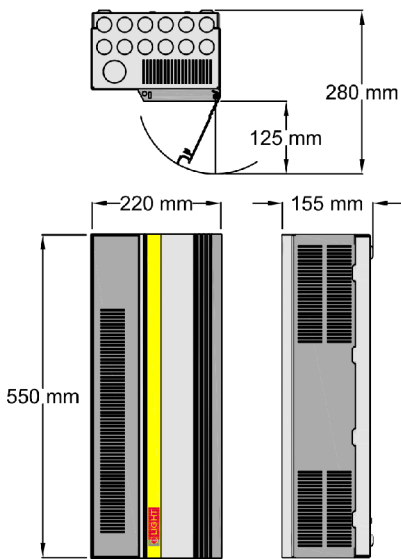

SCI1205 D version - 690x220x155mm

RCBO & RCBOX version - 550x255x155mm

Electrical Data

Maximum Load: 40 Amp single phase @ 40°C

Maximum Channel Current: 5 Amps

Supply: 230 volts +/- 10% 50/60 Hz (optionally, 127 volt 60 Hz)

Protection: 12 x 6 amp MCBs Type C, 6KA rated, Input isolator.

Options:

SCI1205S - Single pole with isolator

SCI1205N - Neutral disconnect with isolator

SCI1205D - Double pole, no isolator

SCI1205RCBO - RCBO Breakers with isolator

SCI1205RCBOX - 12 x SP MCBs with isolator (For field fit of RCBOs)

Load Types:

Incandescent 230 volt lamp

Inductive Wire wound (allow for 10% transformer losses)

Leading edge electronic transformers

Cold cathode (Check the iLight help desk for details)

Minimum Load: 20 watts inductive load per channel

Dimmed Outputs: 12 x 40 Amp Triacs

Switched Outputs:

The Dimmed outputs may be configured as switches, for non-dimmed loads. They require a minimum load of 30mA for them to latch. Before connecting discharge lamps, consult iLight.

Terminal Sizes:

Incoming supply, max' cable size: 10mm²

Loads, max' cable size: 1 x 4mm² or 2 x 2.5mm² per circuit

iCANnet™ network cable size: 5 x 1mm²

Audio Visual Port: RS485 2 x 1mm²

Auxiliary over-ride input: 2 x 1mm²

Memory:

FLASH memory to be able to upgrade firmware

EEPROM for 128 scene memory

Fade Times: 0.1 seconds to 60 minutes

Mains Stabilisation: 50:1

Other inductive source controllers: SCI0405, SCI0410, SCI0805, SCI1210, SCI1220 and the SCMI0402.

Typical Schematic

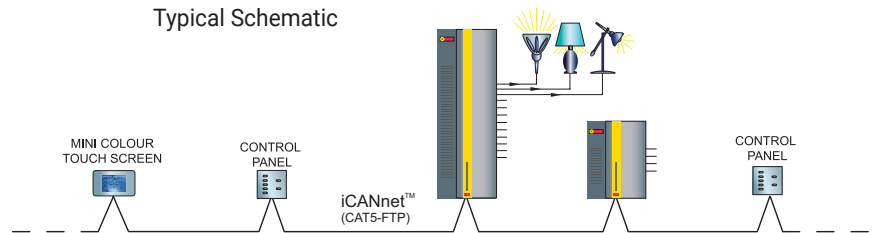

Contact Us

+44 (0)1923 495495

enquiries@iLight.co.uk

www.iLight.co.uk

Cooper Lighting Solutions
20 Greenhill Crescent,
Watford Business Park,
Watford, Herts, WD18 8JA. UK

Changes to the products, to the information contained in this document, and to prices are reserved; so are errors and omissions.

iLight is a registered trademark.

All other trademarks are property of their respective owners.