

AXCS01SRJ

Combined PIR, Daylight and I/R Sensor

Key Features

- Excellent PIR sensitivity to small movements using Quad-Pyro technology
- Greater Sensor stability with reduced noise susceptibility
- 360 degree detection area
- Multiple PIR outputs may be used in Parallel for larger areas of coverage
- Daylight level detector with directional aspect
- Detectors sit flush mounted in the ceiling tile
- Compact 49mm Diameter size for recess installation in Chilled Beam and In fill Plate application
- Simple extension connection using RJ12 connector on rear of unit
- Supplied complete with 5 metre lead to connect to Lighting Control Systems
- CE compliant to all relevant standards
- Designed and manufactured to ISO9001:2015 standards

Overview

This low voltage multi sensor combines PIR presence detection and a photocell in one compact flush mounting design using an RJ12 connector on the rear of the unit.

The action of the photocell and PIR presence detector are separate. When used in conjunction with an iLight UIS Sensor Interface a third infra-red receiver mode is also enabled. The infra-red receiver may be used to select scenes, turn lighting on/off and adjust levels locally with the iLight remote controller (HH17IR).



Ideal for intelligent lighting control systems that deploy system programmed intelligence. This multi sensor is perfect for applications where space is at a premium.

The AXCS01SRJ sensor's combined features ensure maximum energy savings as well as great flexibility for the user.



Suitable For

- Cellular office
- Open plan office
- School classroom
- Lecture theatre
- Retail complex
- Public library
- Sports hall
- Airport terminal
- Hospital wards
- Factory production area
- Corridor & staircases
- Foyer & atriums
- Plant room
- Storeroom
- Consulting room
- Meeting room

Technical Information

Fixing: 2 x Spring Clip
 Mounting Hole Diameter: 40 to 45mm Diameter depending on ceiling material
 Weight: 35g
 Temperature: 0 to 45°C (Non Condensing)
 Supply: 12 - 24V dc (Regulated)
 Construction: Circular Plastic Housing UL94 V0 rated
 Load data: 8m A @ 15V
 Max recommended mounting height: 3.4m



Remote Controller - HH171R
(Order Separately)

Dimensions

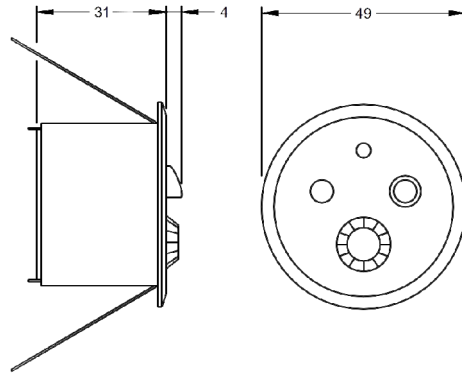

Surface mounting box - AX-SMA1
(Order Separately)

Detection

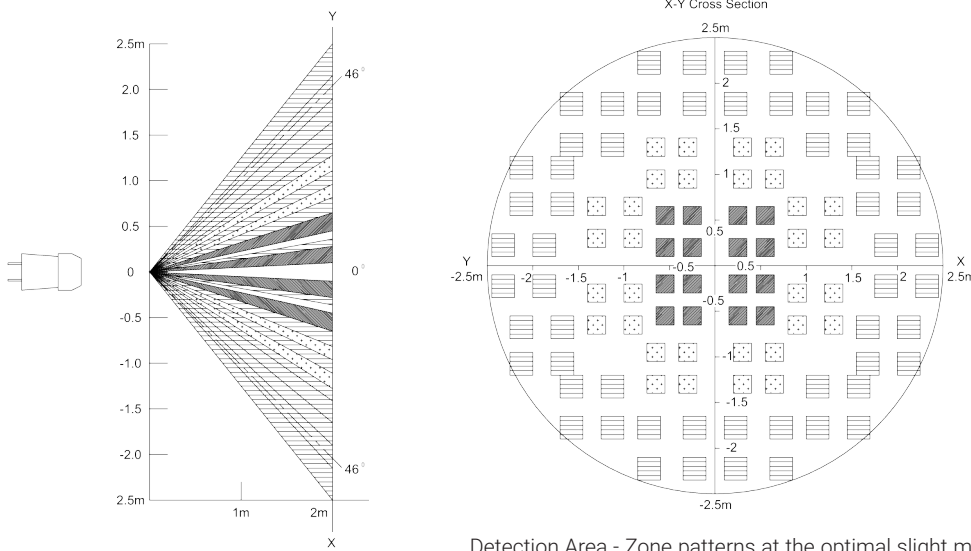

Detection Area - Zone patterns at the optimal slight motion detection distance of 2m from sensor

The differences in the detection zone patterns are indicative of the projections of the 26 lenses with single focal point and with three optical axis.

An object whose temperature differs from the background temperature and which crosses inside the detection zone will be detected.

Detection range is typically calculated at the working plane (900mm off the floor)

Contact Us

+44 (0)1923 495495

enquiries@iLight.co.uk

www.iLight.co.uk

Cooper Lighting Solutions
 20 Greenhill Crescent,
 Watford Business Park,
 Watford, Herts, WD18 8JA. UK

Changes to the products, to the information contained in this document, and to prices are reserved; so are errors and omissions.

iLight is a registered trademark.

All other trademarks are property of their respective owners.

© 2020 Cooper Lighting Solutions
 All Rights Reserved

AXCS01SRJ Rev8 0520

