

# UIS

## Universal Interface - Sensors

### Key Features

- 3 x connections for sensors to iCANnet™ network.
- RJ12 type sockets for rapid sensor connection.
- 3 independant daylight linking engines.
- Presence or absence detection support.
- Infra-red support for HH171R remote controller.
- Supports Infra-red identification.
- 16 Sequences, each with a maximum of 128 actions.
- Configuration stored in Non Volatile EEPROM
- Firmware storage in reflashable FLASH memory over iCAN network
- Status LEDs.
- CE compliant to all relevant standards.
- Designed and manufactured to ISO 9001:2015 standards.

### Mechanical

Temperature Range: 0°C to +40°C  
Humidity: 5 - 95% non condensing  
Material: 2-part aluminum housing.  
Mounting: 6 holes for screw mounting.

### Electrical

Supply: 12VDC via the iCANnet™ network

Network termination: Screw terminals within two part connectors, able to accept 1.5mm<sup>2</sup> stranded or solid wire.

3 x RJ12 connections to AXCS01SRJ  
Combined Sensor and others - Consult iLight for more information.

### Overview

The UIS enables 3 separate sensor groups with 6 sensors in total to be connected to iLight's iCANnet™ lighting control network. (Max cable length for each group 30m). Each sensor can be either a single occupancy detector or daylight sensor or a combined PIR, Photocell with built in infra-red control.

Each UIS installed adds three independant daylight linking engines to the network making this unit ideal for maximising daylight harvesting across all areas.

This small compact device can be deployed anywhere on the iCANnet™ network and uses RJ12 sockets and cables for rapid sensor installation.

### Accessories:

- AXCS01SRJ - Low Voltage Multi Sensor.
- AXCA05RJ - 5m Cable RJ12 to RJ12 (LSOH)
- AX-FFRJ12 - RJ12 to RJ12 Female Coupler
- AX-2FIMRJ12 - 2 Female to 1 Male Doubler



### Dimensions

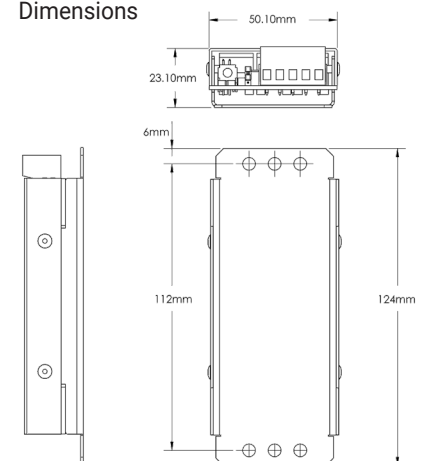

### Contact Us

+44 (0)1923 495495

enquiries@iLight.co.uk

www.iLight.co.uk

**Cooper Lighting Solutions**  
20 Greenhill Crescent,  
Watford Business Park,  
Watford, Herts, WD18 8JA. UK

Changes to the products, to the information contained in this document, and to prices are reserved; so are errors and omissions.

iLight is a registered trademark.

All other trademarks are property of their respective owners.

© 2020 Cooper Lighting Solutions  
All Rights Reserved

UIS Rev6 0520