

MPAD-C-12-24V

Ceiling mounted microwave presence/absence detector

Key Features

- For connection to iCAN networks via UIM, UIG-2, UIS or DALI-I-U devices
- Microwave Sensor: Detects movement within the unit's detection range, allowing load control in response to changes in occupancy
- Light Level Sensor: An integral adjustable photocell allows the lights to be kept off if there is sufficient ambient light
- Status LEDs
- Switch Input Connector: Two input terminals can be used to manually override the lights on or off

Achievable Energy Savings

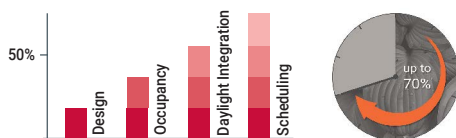

Code Compliance

- Improves BREEAM & LEED scoring for building sustainability
- Contributes to energy reduction targets under Climate Change Levy (CCL) and Carbon Reduction Commitment (CRC)
- Qualifies for Enhanced Capital Allowance (ECA) applications
- Delivers lighting control requirements under UK Building Regs - L2a & L2b and BRE: 498

Overview

The MPAD-C-12-24V microwave presence/absence detector provides automatic control of lighting, heating and ventilation loads when connected to the iCAN network*.

The MPAD-C-12-24V detects movement using a highly sensitive microwave detector. This works by emitting low power microwave signals and measuring the reflections as the signals bounce off moving objects.

This unit can operate both in presence and absence mode as well as in response to a user defined daylight threshold level.

System timeout periods are adjusted in iCANsoft.

The MPAD-C-12-24V may be powered from the iCAN network supply.

Detection

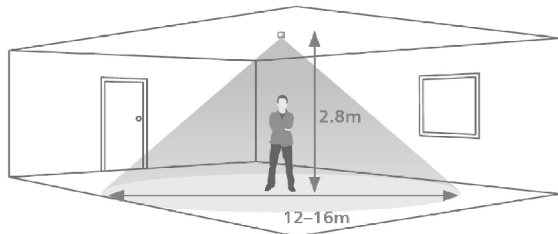

Area of high sensitivity  Area of lower sensitivity 

Ideal for larger offices and other open areas.

Maximum recommended mounting height: 3m

Technical Specifications

Weight: 0.15kg

Supply Voltage: 12-24V via iCANnet network using UIS, UIG-2, UIM and DALI-I-U devices

Switched Output: Open collector transistor

Supply Current: 75mA (Additional power supply may be required depending on total network load)

Terminal Capacity: 2.5mm²

Temperature: -10°C to 50°C

Humidity: 5 to 95% non-condensing

Material: (casing) Flame retardant ABS and PC/ABS

Type: Class 2

Microwave frequency: 5.8 GHz

Safety: The microwave radiation emitted by these units is extremely low power and complies with ANSI standard "IEEE95.1-1999 Standard for Safety Levels with Respect to Human Exposure to Radio Frequency Electromagnetic Fields 3kHz 300GHz."

IP rating: IP40

Compliance: EMC-2004/108/EC LVD-2006/95/EC

Accessories

SB-C: Surface Mounting Box

SB-C-EX: Surface Mounting Box Extender

PSU15-DIN-C: 15V Power Supply

Remote Control Programmers (ordered separately)

HHR-PROG: Hand held IR programmer for setting sensor timeout, daylight threshold and microwave sensitivity only.

HHR-LCD-PROG: Advanced hand held IR programmer with LCD display for reading and setting sensor timeout, daylight threshold and microwave sensitivity only.

Front features

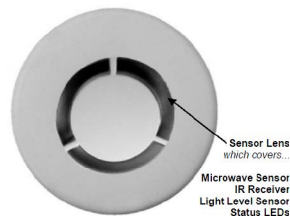

Back features

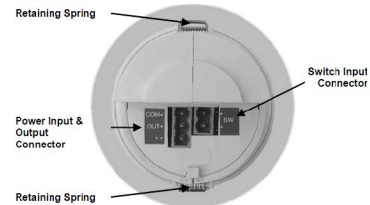

Dimensions

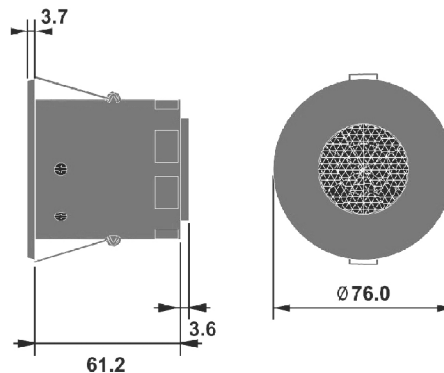

Installation

Choosing a Suitable Location

The detector should be sited so that the occupants of the room fall inside the detection pattern shown opposite.

- Avoid positioning the unit where direct sunlight may enter the sensor element
- Do not site the sensor within 1m of any lighting, forced air heating or ventilation
- Do not fix the sensor to an unstable or vibrating surface
- Avoid metallic objects directly in front of the sensor head

Commissioning

Microwave on/off time and threshold light level can be set via the hand held IR remote for commissioning.

*This sensor is intended for use with UIS, UIG-2, UIM and DALI-I-U devices on iCAN networks. Additional network commissioning will be required.

Contact Us

+44 (0)1923 495495

enquiries@iLight.co.uk

www.iLight.co.uk

Cooper Lighting Solutions
20 Greenhill Crescent,
Watford Business Park,
Watford, Herts, WD18 8JA. UK

Changes to the products, to the information contained in this document, and to prices are reserved; so are errors and omissions.

iLight is a registered trademark.

All other trademarks are property of their respective owners.